

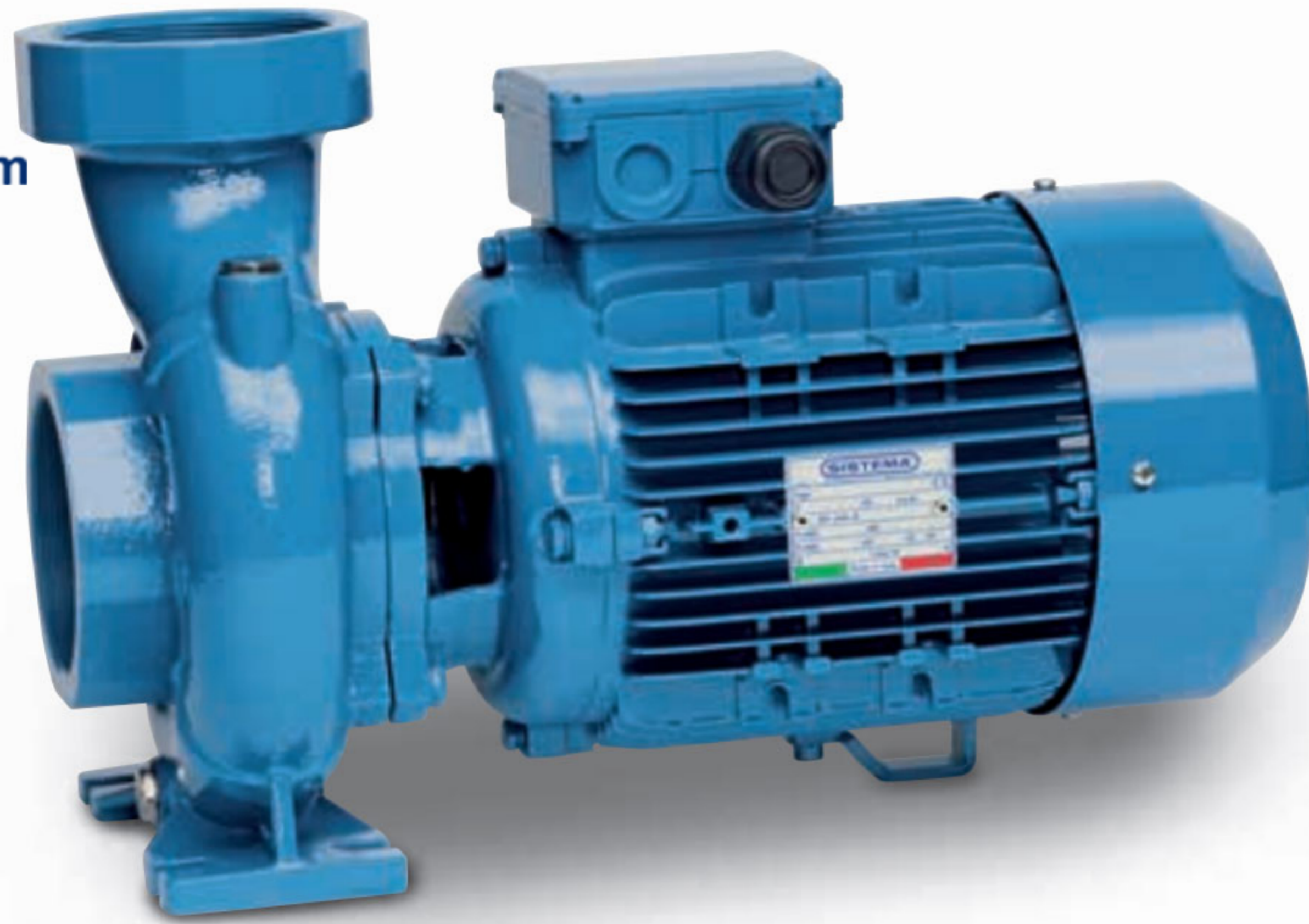

سامان کدو
samankade.com



APPLICAZIONI

Elettropompe centrifughe di scorrimento monogirante. Adatte per pompare acque pulite o liquidi moderatamente carichi di impurità, purchè non aggressivi per i materiali costruttivi della pompa. Adatte negli impianti di irrigazione nel giardino e in agricoltura a scorrimento e negli impianti industriali.

APPLICATION

Centrifugal irrigation pumps with single impeller. Suitable to pump clean water or non-aggressive liquids charged with small solid impurities. To be used in flow irrigation systems in gardening and agriculture and in industrial fittings.

LIMITI D'IMPIEGO

- Temperatura liquido fino a 35°C (per un uso domestico secondo EN 60335-2-41)
- Temperatura max. liquido: 90°C (per altri impieghi)
- Temperatura ambiente fino a 40° C
- Altezza d'aspirazione manometrica fino a 7 mt.
- Servizio continuo

OPERATING CONDITIONS

- Liquid temperature up to 35°C (for home use according to EN 60335-2-41)
- Temperature max. liquid: 90°C (for other uses)
- Ambient temperature up to 40°C
- Total suction lift up to 7 mt.
- Continuous duty

MOTORE

- Monofase 230V-50Hz
- Trifase 230/400V-50Hz
- Motore elettrico ad induzione a 2 poli (n = 2850 min⁻¹)
- Isolamento Classe F
- Protezione IP 55

MOTOR

- Single-phase 230V-50Hz
- Three-phase 230/400V-50Hz
- Two-Pole induction motor (n = 2850 min⁻¹)
- Insulation Class F
- Protection IP 55

MATERIALI

- Corpo pompa Ghisa
- Supporto motore Ghisa
- Girante Ghisa
- Albero motore Acciaio Inox AISI 304
- Tenute meccaniche Ceramica/Grafite/NBR

MATERIALS

- Pump body Cast Iron
- Motor Support Cast Iron
- Impeller Cast Iron
- Shaft with rotor Stainless Steel AISI 304
- Mechanical seal Ceramic/Graphite/NBR

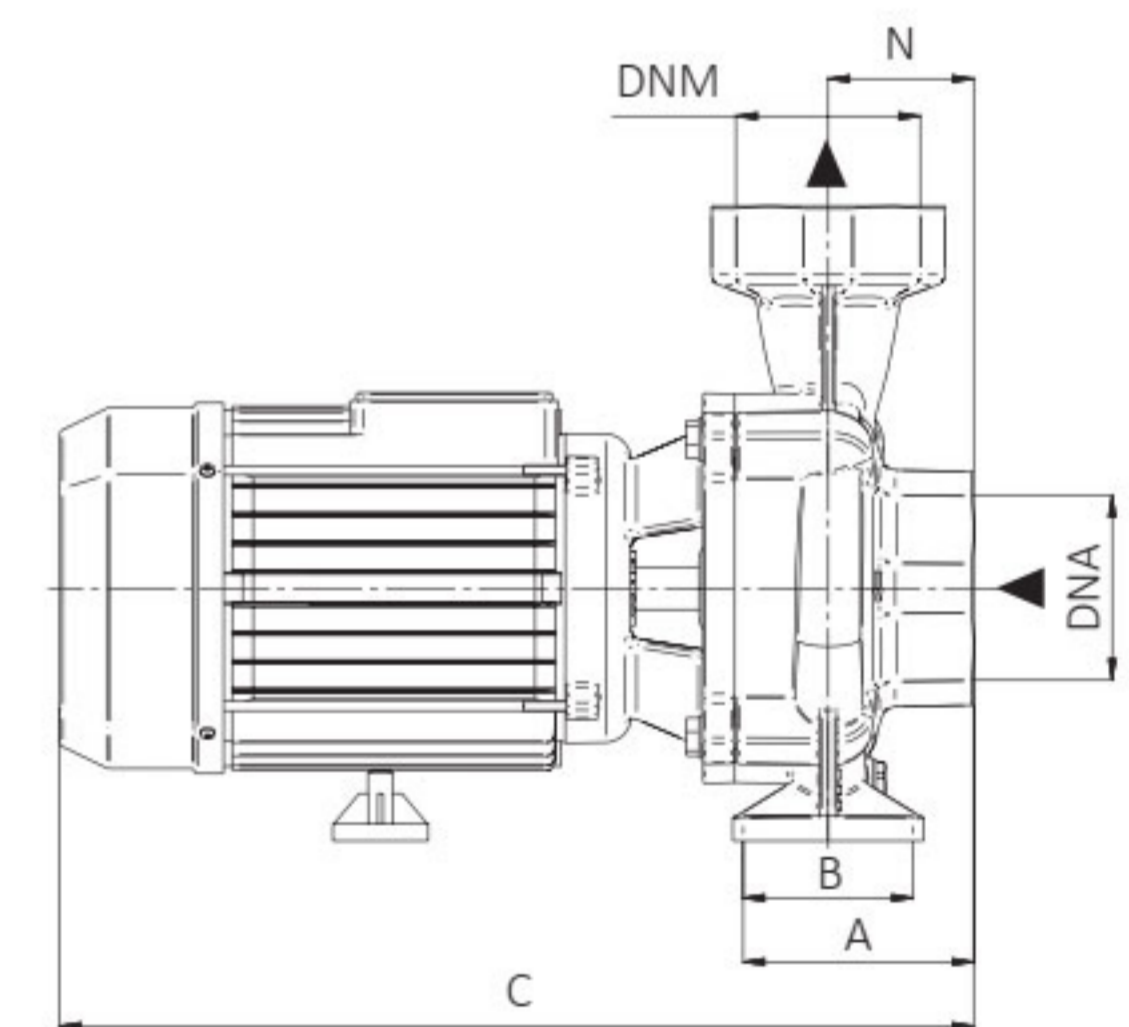
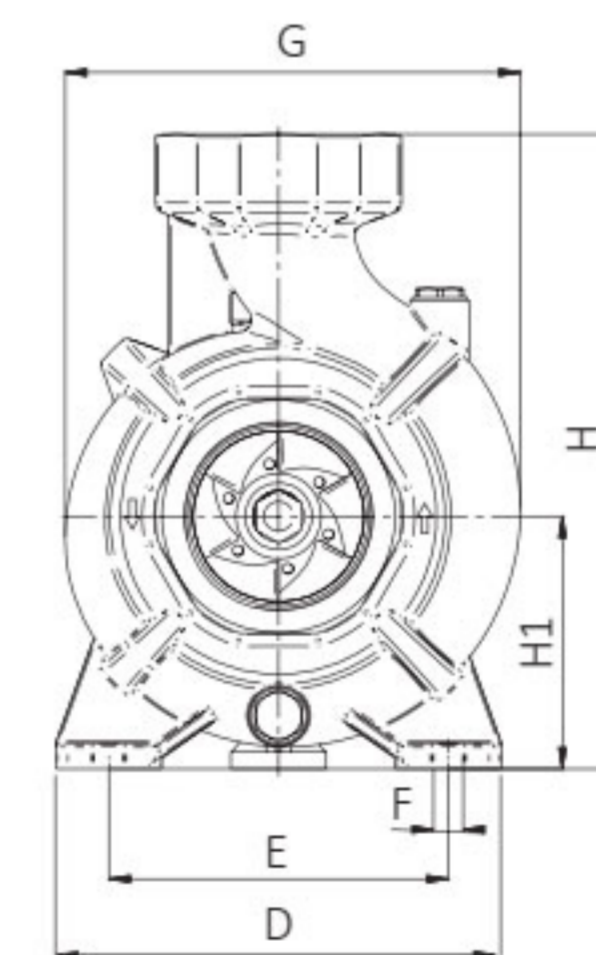
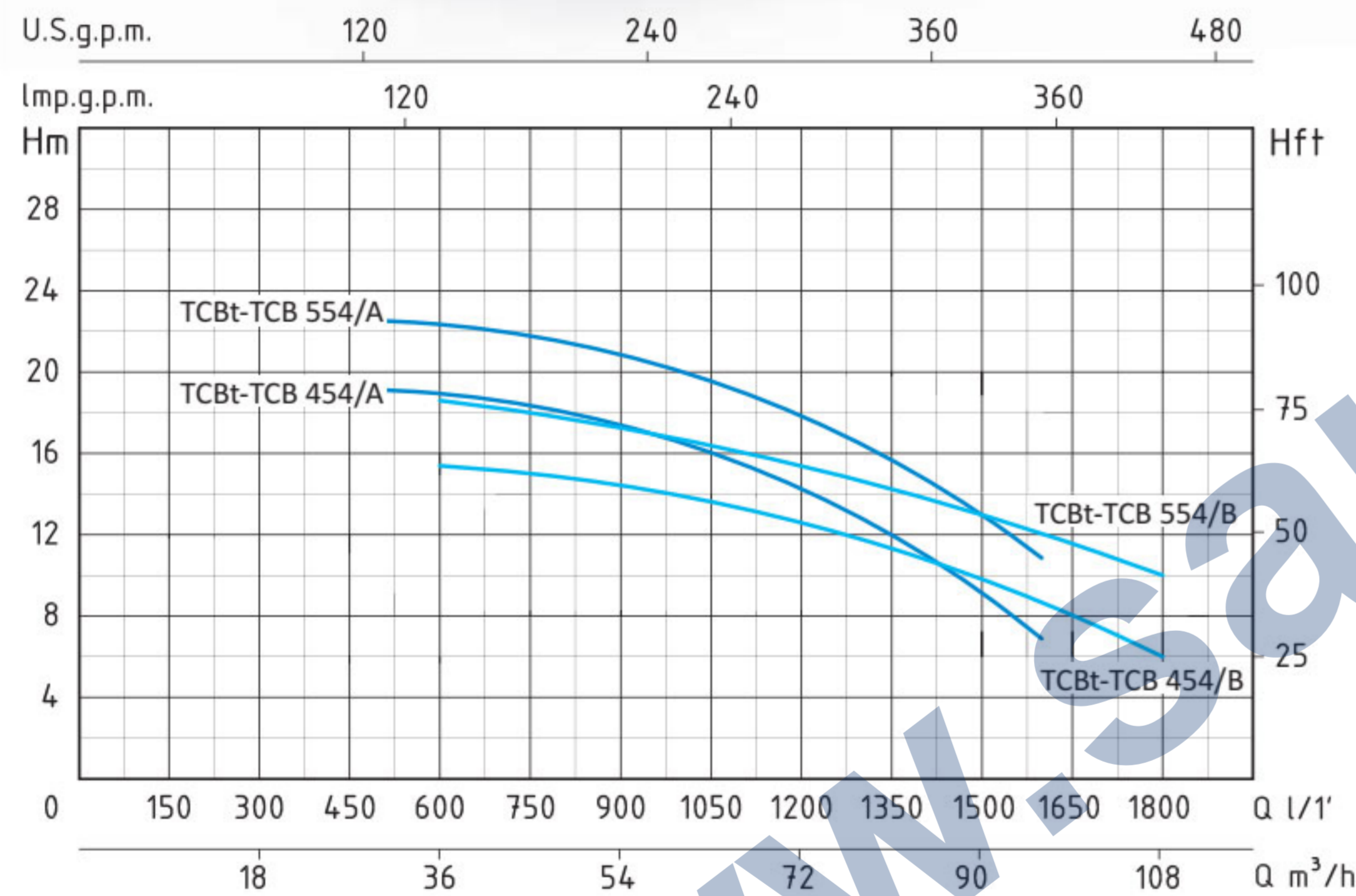

TCB - 50 HZ - 1 PHASE / 3 PHASE

TIPO TYPE	POTENZA NOMINALE NOMINAL POWER	POTENZA ASSORBITA INPUT POWER	AMPERE		Q = PORTATA - CAPACITY																				
			Monofase Single-phase	Trifase Three-phase	m³/h	30	36	42	54	72	84	90	96	102	108										
TCB 454/A	4	3	4,5	20	7,3	19	18,8	18,4	16,7	13	10	8,5	7												
TCB 454/B	4	3	4,5	20	7,3		15,5	15,3	14,8	12,5	10,5	9,5	8,5	7,5	6										
TCB 554/A	5,5	4	5,7	28	9	22,5	22,3	22	20,8	17,5	14,5	13	11												
TCB 554/B	5,5	4	5,7	28	9		18,5	18,3	17,9	16	14	13	12	11	10										

DIMENSIONI mm - DIMENSIONS mm

TIPO - TYPE	DIMENSIONI mm - DIMENSIONS mm														DIMENSIONI DIMENSIONS mm			PESO WEIGHT
Monofase Single-phase	Trifase Three-phase	A	B	C	D	E	F	G	H	H1	N	DNA	DNM	P	L	H	Kg	
TCB 454/A	TCBt 454/A	97,5	60	495	220	165	14	245	330	132	69	4"	4"	269	540	421	45	
TCB 454/B	TCBt 454/B	97,5	60	495	220	165	14	245	330	132	69	4"	4"	269	540	421	45,3	
TCB 554/A	TCBt 554/A	97,5	60	495	220	165	14	245	330	132	69	4"	4"	269	540	421	48,7	
TCB 554/B	TCBt 554/B	97,5	60	495	220	165	14	245	330	132	69	4"	4"	269	540	421	48,9	